

POTTORFF®

Solutions for High Pressure Situations



Heavy-Duty Ultra Low Leakage Control Damper

Created to meet the demanding high pressure air intake and exhaust systems specified on the One World Trade Center.

Our industrial strength airfoil bladed dampers are designed to perform in the most demanding applications where stringent leakage and high pressures are a concern. Designed to perform at 5000 fpm and 32 in.wg, these dampers are tested in-house to ensure the highest level of performance.

Where high pressure performance and positive shut-off are required, we have the solution!

POTTORFF®

Visit www.pottorff.com for more information about this model.

Application

CD-93 and CD-94 industrial control dampers employ heavy duty airfoil blades, a rugged flanged frame, and options for ultra-low leakage in high temperature air and high pressure applications that makes it ideal for high performance air intake and discharge applications where ultra-low leakage is critical.

Ratings

Damper Width	Maximum System Pressure	Maximum System Velocity
12" (305)	32.0 in. wg (8.0 kPa)	5000 fpm (25.4 m/s)
24" (610)	27.0 in. wg (6.7 kPa)	5000 fpm (25.4 m/s)
36" (914)	22.0 in. wg (5.5 kPa)	5000 fpm (25.4 m/s)
48" (1219)	17.0 in. wg (4.2 kPa)	5000 fpm (25.4 m/s)
60" (1524)	12.0 in. wg (3.0 kPa)	4000 fpm (20.3 m/s)

Maximum System Pressure	**Leakage with Seals (cfm/ft ²)	**Leakage with Ultra-Low Leakage Seals (cfm/ft ²)
15.0 in. wg (3.8 kPa)	11.5 (0.06 m ³ /s/m ²)	7.5 (0.04 m ³ /s/m ²)
10.0 in. wg (2.5 kPa)	8.5 (0.04 m ³ /s/m ²)	4.6 (0.02 m ³ /s/m ²)
6.0 in. wg (1.5 kPa)	5.8 (0.03 m ³ /s/m ²)	2.8 (0.02 m ³ /s/m ²)
2.0 in. wg (0.5 kPa)	4.0 (0.02 m ³ /s/m ²)	1.5 (0.01 m ³ /s/m ²)

Temperature: -25°F to 250°F (-32°C to +121°C), available up to 450°F (232°C) when required – consult with Pottorff.

Standard Construction

- Frame:** 8" × 2" × 12 ga. (203 × 51 × 2.8) galvanized steel channel.
- Blades:** 16 gauge (1.5) galvanized steel airfoil. Parallel (model CD-93) or opposed (model CD-94) action.
- Axles:** 3/4" (19) diameter plated steel.
- Linkage:** 3/16" × 3/4" (5 × 19) plated steel tie bars and 3/8" (10) stainless steel pins concealed in frame.
- Bearings:** Stainless steel pressed into frame.
- Control Shaft:** 3/4" × 10" (19 × 254) round drive shaft with shaft support bracket and bearing mounted to damper frame with factory mounted manual locking quadrant.
- Lifting lugs:** 7/8" (22) diameter, one on each side of jamb frame.
- Minimum Size:** CD-93 (one blade): 8" × 10" (203 × 254)
CD-94 (two blades): 8" × 12" (203 × 305)
- Maximum Size:** Single section: 60" × 96" (1524 × 2438)
Multiple sections: Unlimited

Options

- Factory mounted electric or pneumatic actuator.
- Stainless steel construction: 304 316
- Low leakage seals: Silicone blade edge seals are mechanically secured to blade and stainless steel jamb seals.
- Ultra low leakage seals: Silicone blade edge seals are mechanically secured to blade and stainless steel jamb seals. Requires optional 14 gauge (2) blades.
- 14 gauge (2) blades.
- High temperature construction.
- Vertical mounted blades with thrust washers.
- Bolt holes in damper frame:
 - One side Both sides
- Outboard bearings.
- Lifting lugs.
- Extended perimeter mounting flange.

** Results based upon a 36" × 48" (914 × 1219) damper. Maximum single section width for Ultra-Low leakage seals is 48" (1219).

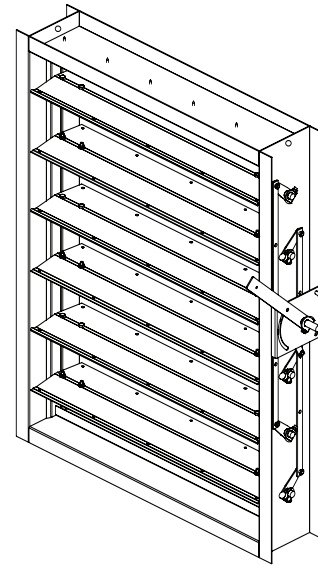

Model CD-94
*Damper dimensions furnished approximately net I.D..

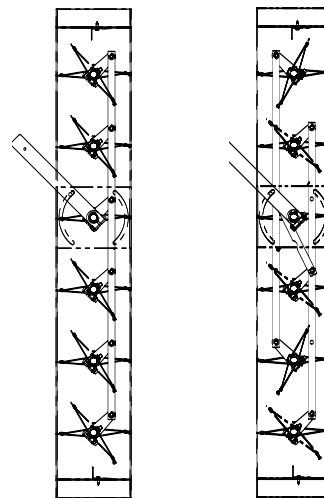

CD-93

CD-94