

The following installation details apply to models **VFD-10, VFD-10D, VFD-10TL and VFD-10D-TL**

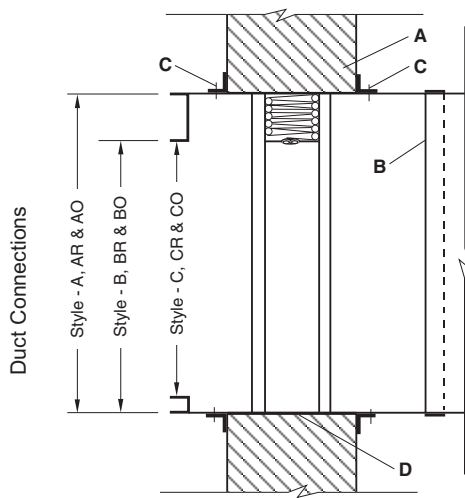

Damper Installation For Typical Fire Rated Partition

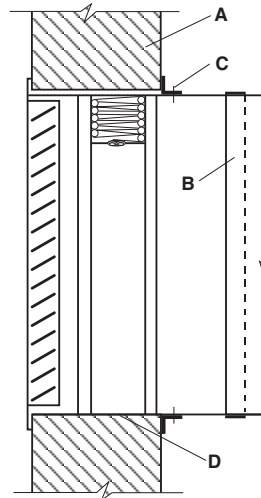

Damper Installation For Typical Flange Termination with Grille / Register

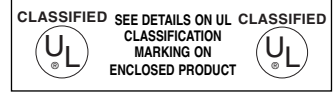

- A. Concrete or masonry fire partition shown. See Wood Stud and/or Steel Stud Framing for Fire Dampers In Drywall and/or Cavity Shaftwall Partitions Supplemental Installation Instructions for further vertical installation details. The opening shall be a minimum of ¼" (6) with a maximum of ¾" (19) larger than the overall damper and sleeve assembly size. When openings are larger than ¾" (19), but less than 6" (152) the mounting angles must be a minimum of 16 gauge (1.5) and must be tall enough to overlap the opening by a minimum of 1" (25). Damper must be installed with leading edge of closed blade within the partition.
- B. For rigid type duct connections, the sleeve shall be a minimum of 16 gauge (1.5) for dampers up to 36" wide by 24" high (914 × 610) and 14 gauge (1.9) for larger units. When lighter gauge sleeves are used, one or more of commonly used breakaway style connections are required. Refer to Sleeve Termination Supplemental Installation Instructions for further details. In no case will the sleeve gauge be less than the duct gauge to which it is connected. Damper sleeve shall not extend more than 6" (152) beyond the rated partition unless an access door or Smoke Detector is installed in the sleeve which then permits the extension to be a maximum of 16" (406).
- C. Mounting angles shall be a minimum of ¾" × 1-½" tall × 20 gauge (19 × 38 × 1.0). For opening sizes ≤ 80" wide (2032), 96" high (2438), and not exceeding 26.67 square feet in area retaining angles are only required on one side of the partition and must be attached to the sleeve and the partition. For larger openings (or optional on smaller openings), 1-½" × 1-½" × 16 gauge (38 × 38 × 1.5). retaining angles are required on both sides of the partition and must be attached to the sleeve. Attachment to the sleeve shall be with No. 10 (M5) screws or bolts, ⅜" (4.8) diameter steel rivets, Quick-Lock joints or welds, at 12" (305) o.c. maximum. Attachment to partition/opening shall be with min. No. 10 fasteners with a minimum length as follows: For metal stud and the angles under the drywall, the fasteners must be a min. ½" long. For metal stud and the angles over the drywall the fastener must be a min. ½" longer than the thickness of the drywall. i.e. if the partition has one layer of ⅝" drywall on the attachment side, the screws must be ½" + ⅝" = 1-⅜" long. For wood stud openings, the min. length is 1-½" longer than the thickness of drywall on the attachment side. For concrete or masonry openings, the anchors must be for min. No. 10 fasteners- screws or bolts. In lieu of masonry anchors and bolts/screws, self-tapping masonry screws can be used. The fasteners in the partition should be located such that they are ½" below the top of the 1-½" flange of the retaining angles. Fasteners in the partition should be spaced 12" o.c. max. A minimum of two connections per side, top and bottom. A minimum ¾" × 20 gauge (19 × 1) flange termination may be used in lieu of mounting angles. Refer to Sleeve Termination Supplemental Installation Instructions and Framing for Fire Dampers for further details. Ensure that attachment device does not interfere with the operation of the damper and the free movement of the damper blades. Note: If optional sealing between the retaining angle (or flange) leg and the surface of the partition, wall, or floor, and/or between the retaining angle leg and the surface of the damper sleeve is required, the following sealants may be used: Dow Corning 732 or DOWSIL 732 or GE RTV 108 or SCS 1201 RTV. These sealants should be applied such that they do not intrude into the annular space between the outside surface of the damper sleeve and the opening of the partition, wall, or floor, into which the damper/sleeve is being installed.

Note:

Annular space between damper sleeve and wall opening shall not be filled with firestop materials such as fill, void or cavity materials.

*Maximum single section is 36" × 36" (914 × 914) for multiple sections larger than 36" × 96" (914 × 2438) or 72" × 48" (1829 × 1219)

DUCT SIZES	Model VFD-10		Model VFD-10D		Model VFD-10-TL	Model VFD-10D-TL
	GALVANIZED STEEL	STAINLESS STEEL	GALVANIZED STEEL	STAINLESS STEEL	GALVANIZED STEEL	GALVANIZED STEEL
Maximum Single Section	48" × 48" (1219 × 1219)	40" × 40" (1016 × 1016)	*36" × 48" (914 × 1219)	36" × 36" (914 × 914)	36" × 48" (914 × 1219)	36" × 48" (914 × 1219)
Maximum Multiple Section	120" × 80" or 80" × 120" (3048 × 2032)(2032 × 3048)	80" × 40" or 40" × 80" (2032 × 1016)(1016 × 2032) 108" × 24" (2743 × 610)	*120" × 72" or 72" × 120" (3048 × 2032)(2032 × 3048)	NA	36" × 72" or 72" × 36" (915 × 1829)(1829 × 915)	36" × 72" or 72" × 36" (915 × 1829)(1829 × 915)
Minimum	4" × 4" (102 × 102)	4" × 4" (102 × 102)	6" × 6" (152 × 152)	6" × 6" (152 × 152)	4" × 4" (102 × 102)	6" × 6" (152 × 152)

Product Listing Underwriter's Laboratories file #R11767 and CSFM File # 3225-0368:101

Information is subject to change without notice or obligation.

NOTE: Dimensions in parentheses () are millimeters.

The following installation details apply to models **VFD-10**, **VFD-10D**, **VFD-10TL** and **VFD-10D-TL**

- D. When joining multiple sections or fastening the dampers to the sleeve, the damper shall be fastened with 3/16" (4.8) diameter steel rivets, Quick-Lock joints, welds or No. 10 (M5) bolts or sheet metal screws at 8" (203) o.c. maximum if multiple sections assemblies are smaller than 36" x 96" (914 x 2438) and 72" x 48" (1829 x 1219) or 6" (152) o.c. maximum for multiple sections larger than 36" x 96" (914 x 2438) and 72" x 48" (1829 x 1219). There must be a minimum of two connections per side, top and bottom.

On multiple sections larger than 36" x 96" (914 x 2438) and 72" x 48" (1829 x 1219) the maximum single section size shall be 36" x 36" (914 x 914).

For assemblies multiple sections wide and multiple sections high a minimum 14 gauge x 5" (127) wide supplemental steel mullion plate is required. The mullion plate length should be either full length or full height of the multiple sections assembly. The mullion plate must be installed between adjacent damper frames running parallel to the sleeve/duct width/height. Mullions are not required for dampers assemblies that are single sections wide and multiple high or single sections high and multiple wide.

The support mullion must be attached to the damper frames using welds or No. 10 (M5) bolts, sheet metal screws or minimum 3/16" (4.8) diameter steel rivets at 6" (152) o.c. maximum and 1" maximum from the frame corner.

