

The following installation details apply to models **FD-140** and **FD-150**

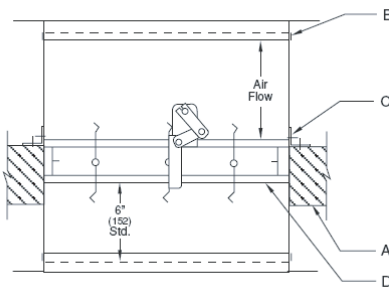

**Horizontal Mount  
(Single Side Mounting Angle)**

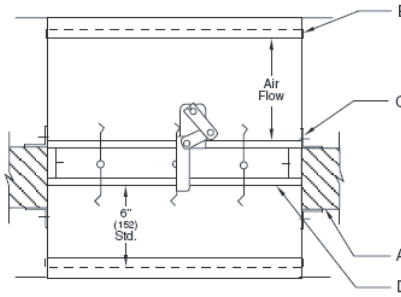

**Horizontal Mount  
(2-sided Mounting Angles)**



Illustrations show triple-V bladed (140 type), steel airfoil blade (150 type) similar.



- A.** Concrete or masonry fire partition shown. The opening shall be a minimum of ¼" (6) with a maximum of ¾" (19) larger than the overall damper and sleeve assembly size. When openings are larger than ¾" (19), but less than or equal to 6" (152) the mounting angles must be a minimum of 16 gauge (1.5) and must be wide enough to overlap the opening by a minimum of 1" (25). (Note: For Model FD-140 dampers installed in concrete floors where the opening is 6" (152) or larger, the dampers may be installed in accordance with the Through-Penetration Firestop System F-A-7019 detailed in the UL Fire Resistance Directory.) The damper must be installed with leading edge of closed blade within the partition.
  - B.** For rigid type duct connections, the sleeve shall be a minimum of 16 gauge (1.5) for dampers up to 36" wide by 24" high (914 x 610) and a minimum of 14 gauge (1.9) for larger units. When lighter gauge sleeves are used, one or more of commonly used breakout style connections are required. Refer to Sleeve Termination Supplemental Installation Instructions for further details. In no case will the sleeve gauge be less than the duct gauge to which it is connected. Damper sleeve shall not extend more than 6" (152) beyond the rated partition unless an access door or Smoke Detector is installed in the sleeve which then permits the extension to be a maximum of 16" (406).
  - C.** Mounting angles shall be a minimum 1-½" x 1-½" x 16 gauge (38 x 38 x 1.5). Mounting angles are only required on the top side of the opening and must be attached to the sleeve at 6" (152) o.c. maximum, to the partition at 24" (610) o.c. maximum. There must be a minimum of two fasteners per side to both the sleeve and partition on all four sides. Alternately, mounting angles may be installed on both sides of the partition and must be attached only to the sleeve at 12" (305) o.c. maximum. There must be a minimum of two connections per side on all four sides. Attachment to the sleeve shall be with a minimum of #10 (M5) screws or bolts, ⅜" (4.8) diameter steel rivets, Quick-Lock joints, or welds. Attachment to the partition shall be with a minimum of #10 (M5) steel fasteners: anchors, bolts, or self-tapping masonry screws. A minimum ¾" x 20 gauge (19x1) flange termination may be used in lieu of mounting angles. Ensure that the attachment device does not interfere with the operation of the damper and the free movement of the damper blades.
- Note:** If optional sealing between the mounting angle (or flange) leg and the surface of the partition, or floor, and/or between the mounting angle leg and the surface of the damper sleeve is required, the following sealants may be used: Dow-Corning 700 or 732 or GE RTV 108 or SCS 1201 RTV. These sealants should be applied such that they do not intrude into the annular space between the outside surface of the damper sleeve and the opening of the partition, or floor, into which the damper sleeve is being installed. Annular space between damper sleeve and opening shall not be filled with firestop materials such as fill, void or cavity materials.
- D.** When joining multiple sections or fastening the damper to the sleeve, the damper shall be fastened with minimum ⅜" (4.8) diameter steel rivets, Quick-Lock Joints, welds or #10 (M5) bolts or sheet metal screws at 8" (203) o.c. maximum. There must be a minimum of two connections per side, top and bottom. For FD-150 installations more than one damper high and three dampers wide, a minimum 14 gauge x 5" (1.9 x 127) supplemental steel mullion is required. The mullion should be the same length as the opening/duct height and must be installed between the damper frames running parallel to the opening/duct height, at the center of the assembly. Support mullions should be attached to the damper frames using the same fasteners indicated previously in this section.

DUCT SIZES	GALVANIZED STEEL		STAINLESS STEEL
	HORIZONTAL		HORIZONTAL
	FD-140	FD-150	FD-140
Maximum Single Section	36" x 48" (914 x 1219)	32" x 48" (813 x 1219)	36" x 48" (914 x 1219)
Maximum Multiple Section+	108" x 48"* (2743 x 1219)	144" x 96"* (3658 x 2438)	N/A

\* Individually sleeved dampers can be installed in partitions wider than the maximum U.L. multiple section size using the Support Mullion for Oversized Floor Openings. See Support Mullion for Oversized Floor Openings Installation Instructions for further details.

Underwriter's Laboratories file #R11767. The product is also listed by CSFM File # 3225-0368:110.

+Sizes larger than 72" x 48" (1828 x 1219) or 36" x 96" (914 x 2438) require electric actuators and a HS-10 fire closure device.

Information is subject to change without notice or obligation.

**NOTE:** Dimensions in parentheses ( ) are millimeters.

The following installation details apply to models **FD-140** and **FD-150**

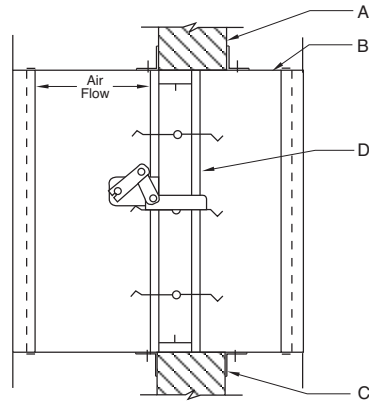

**Vertical Mount**

Illustrations show triple-V bladed (140 type), steel airfoil blade (150 type) similar.

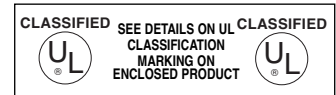

- A.** Concrete or masonry fire partition shown. See Wood Stud and/or Steel Stud Framing for Fire Dampers In Drywall and/or Cavity Shaftwall Partitions Supplemental Installation Instructions for further vertical installation details. The opening shall be a minimum of ¼" (6) with a maximum of ¾" (19) larger than the overall damper and sleeve assembly size. When openings are larger than ¾" (19), but less than 6" (152) the mounting angles must be a minimum of 16 gauge (1.5) and must be tall enough to overlap the opening by a minimum of 1" (25). The damper must be installed with leading edge of closed blade within the partition.
- B.** For rigid type duct connections, the sleeve shall be a minimum of 16 gauge (1.5) for dampers up to 36" wide by 24" high (914 x 610) and 14 gauge (1.9) for larger units. When lighter gauge sleeves are used, one or more of commonly used breakaway style connections are required. Refer to Sleeve Termination Supplemental Installation Instructions for further details. In no case will the sleeve gauge be less than the duct gauge to which it is connected. Damper sleeve shall not extend more than 6" (152) beyond the rated partition unless an access door or Smoke Detector is installed in the sleeve which then permits the extension to be a maximum of 16" (406).
- C.** Mounting angles shall be a minimum of ¾" x 1-½" tall x 20 gauge (19 x 38 x 1.0). For opening sizes ≤80" wide (2032), 96" tall (2438) and not exceeding 26.67 square feet (2.48 square meters) mounting angles are required on only one side of the partition and must be attached to the sleeve and the partition. For larger openings (or optional on smaller openings) 1-½" x 1-½" x 16 gauge (38 x 38 x 1.5) mounting angles are required on both sides of the partition and must be attached to the sleeve only. Attachment to the sleeve shall be with a minimum of #10 (M5) screws or bolts, ⅜" (4.8) diameter steel rivets, Quick-Lock joints, or welds at 12" (305) o.c. maximum. Attachment to the partition/opening shall be with minimum #10 (M5) fasteners with a minimum length as follows: For metal studs and the angles under the drywall, the fasteners must be a minimum of ½" (12.7) long. For metal studs and the angles over the drywall the fastener must be a minimum of ½" (12.7) longer than the thickness of the drywall, i.e. if the partition has one layer of ⅝" (15.9) drywall on the attachment side, the screws must be ½" + ⅝" = 1 ⅛" (12.7 + 15.9 = 28.6) long. For wood stud openings, the minimum length is 1-½" (38) longer than the thickness of the drywall on the attachment side. For concrete or masonry openings, the anchors must be a minimum of #10 (M5) fasteners: screws, bolts or self-tapping masonry screws. Fasteners in the partition should be spaced at 12" (305) o.c. maximum. There must be a minimum of two connections per side on all four sides. A minimum of ¾" x 20 gauge (19 x 1) flange termination may be used in lieu of mounting angles. Refer to Sleeve Termination Supplemental Installation Instructions and Framing for Fire Dampers for further details. Ensure that the attachment device does not interfere with the operation of the damper and the free movement of the damper blades.
- Note:** If optional sealing between the mounting angle (or flange) leg and the surface of the partition, wall, or floor and/or between the mounting angle leg and the surface of the damper sleeve is required, any of the following sealants may be used: Dow-Corning 700 or 732 or GE RTV 108 or SCS 1201 RTV These sealants must be applied such that they do not intrude into the annular space between the outside surface of the damper sleeve and the opening of the partition, wall or floor into which the damper/sleeve is installed. The annular space between damper sleeve and wall opening must not be filled with firestop materials such as fill, void, or cavity materials.
- D.** When joining multiple sections or fastening the damper to the sleeve, the damper shall be fastened with ⅜" (4.8) diameter steel rivets, Quick-Lock Joints, welds or #10 (M5) bolts or sheet metal screws at 8" (203) o.c. maximum. There must be a minimum of two connections per side, top and bottom. For vertical installations >108" wide x 96" high (2743 x 2438), a minimum 14 gauge x 5" wide (1.9 x 127) supplemental steel mullion is required. The mullion must be the same length as the opening/duct height. The mullion must be installed between the damper frames running parallel to the opening/duct height located at the center of the assembly. Supplemental support mullions should be attached to the damper frames using any of the same fasteners indicated previously in this section.

DUCT SIZES	GALVANIZED STEEL		STAINLESS STEEL
	FD-140	FD-150	FD-140
Maximum Single Section	36" x 48" (914 x 1219)	32" x 48" (813 x 1219)	36" x 48" (914 x 1219)
Maximum Multiple Section+	144" x 96" (3658 x 2438)	144" x 96" (3658 x 2438) or 60" x 150" (1524 x 3810)	N/A

Underwriter's Laboratories file #R11767. The product is also listed by CSFM File # 3225-0368:110.

+Sizes larger than 72" x 48" (1828 x 1219) or 36" x 96" (914 x 2436) require electric actuators and a HS-10 fire closure device.