

## Application

The SAJ-1235 acoustical louver incorporates a J-blade and is designed for intake and exhaust application where maximum noise reduction is required. The SAJ-1235 is available in a wide array of finishes including custom color matching.

## Standard Construction

**Material:** Galvanized steel.

**Frame:** 12" deep × 16 ga. thick (305 × 1.6) channel.

**Blades:** 35° × 22 ga. (0.85) thick J-style with a 26 ga. (0.55) thick perforated backing packed with noncombustible insulating material.

**Screen:** 1/2" × 0.063" (12.7 × 1.6) expanded and flattened aluminum.

**Mullion:** Visible.

**Minimum Size:** 12" × 32" (305 × 813)

**Maximum Size:** Single section: 48" × 96" (1219 × 2438)  
Multiple section: Unlimited

## Options

- Factory finish:
  - Polyester Powder (Galvannealed steel construction only)
  - Baked Enamel (Galvannealed steel and aluminum construction only)
  - Prime Coat (Galvannealed steel and aluminum construction only)
  - High Performance Fluoropolymer - 100% Newlar/70% resin Kynar (Aluminum construction only)
- 1 1/2" (38) flange frame.
- Welded construction.
- Alternate bird or insect screens.
- Insulated or non-insulated blank-off panels.
- Filter racks.
- Hinged frame.
- Heavy duty 16 ga. (1.6) construction.
- Alternate material:
  - 304 stainless steel construction.
  - Aluminum construction.
  - Galvannealed steel construction.

## Ratings

**Free Area:** [48" × 48" (1222 × 1222) unit]: 4.9 ft<sup>2</sup> (0.45 m<sup>2</sup>)  
30.6%

### Performance @ Beginning Point of Water Penetration

**Free Area Velocity:** 924 fpm (4.70 m/s)  
**Air Volume Delivered:** 4528 cfm (2.14 m<sup>3</sup>/s)  
**Pressure Loss:** 0.08 in.wg. (20 Pa)

**Velocity @ 0.15 in.wg. Pressure Loss:** 1230 fpm (6.25 m/s)

**Design Load:** 30 psf

### Acoustical Performance:

Octave Band	2	3	4	5	6	7
Center Freq. (hz)	125	250	500	1000	2000	4000
Transmission Loss	9	11	16	21	25	22
Noise Reduction	15	17	22	27	31	28

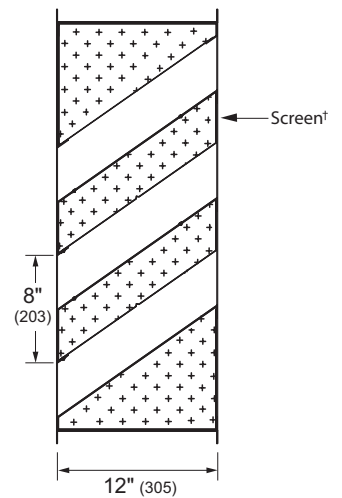
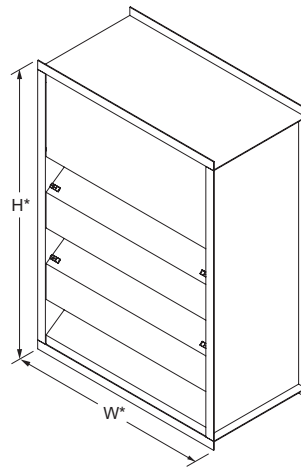

Model **SAJ-1235**  
(standard)

\*Louvers dimensions furnished approximately 1/2" (13) undersize.

**Vertical Section**

<sup>1</sup>Screen adds approximately 3/16" (5) to louver depth.

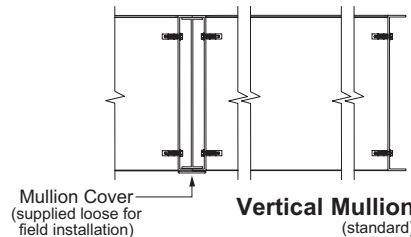

**Vertical Mullion**  
(standard)

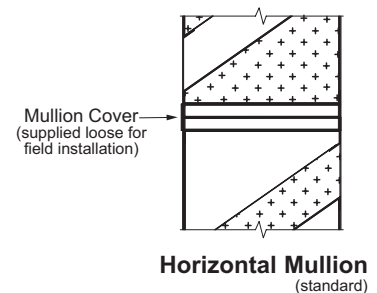

**Horizontal Mullion**  
(standard)

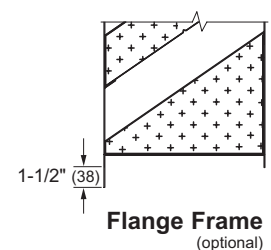

**Flange Frame**  
(optional)

### Certified Ratings:

Pottorff certifies that the model SAJ-1235 shown herein is licensed to bear the AMCA seal. The ratings shown are based on test and procedures performed in accordance with AMCA Publication 511 and comply with the requirements of the AMCA Certified Ratings Program. The AMCA Certified Ratings seal applies to air performance and water penetration ratings.



# Performance Data

## Free Area (ft<sup>2</sup>)

		Width (Inches)																		
		12	18	24	30	36	42	48	54	60	66	72	78	84	90	96	102	108	114	120
Height (Inches)	32	0.6	1.0	1.4	1.8	2.2	2.6	2.9	3.3	3.7	4.1	4.5	4.9	5.2	5.6	6.0	6.4	6.8	7.2	7.5
	40	0.9	1.4	1.9	2.4	2.9	3.4	3.9	4.4	4.9	5.5	6.0	6.5	7.0	7.5	8.0	8.5	9.0	9.6	10.1
	48	1.1	1.7	2.3	3.0	3.6	4.3	4.9	5.5	6.2	6.8	7.5	8.1	8.7	9.4	10.0	10.7	11.3	11.9	12.6
	56	1.3	2.0	2.8	3.6	4.3	5.1	5.9	6.7	7.4	8.2	9.0	9.7	10.5	11.3	12.0	12.8	13.6	14.3	15.1
	64	1.5	2.4	3.3	4.2	5.1	6.0	6.9	7.8	8.7	9.6	10.4	11.3	12.2	13.1	14.0	14.9	15.8	16.7	17.6
	72	1.7	2.7	3.8	4.8	5.8	6.8	7.8	8.9	9.9	10.9	11.9	13.0	14.0	15.0	16.0	17.1	18.1	19.1	20.1
	80	1.9	3.1	4.2	5.4	6.5	7.7	8.8	10.0	11.1	12.3	13.4	14.6	15.7	16.9	18.0	19.2	20.3	21.5	22.6
	88	2.1	3.4	4.7	6.0	7.2	8.5	9.8	11.1	12.4	13.6	14.9	16.2	17.5	18.8	20.0	21.3	22.6	23.9	25.2
	96	2.3	3.8	5.2	6.6	8.0	9.4	10.8	12.2	13.6	15.0	16.4	17.8	19.2	20.6	22.0	23.5	24.9	26.3	27.7
	104	2.6	4.1	5.6	7.2	8.7	10.2	11.8	13.3	14.8	16.4	17.9	19.4	21.0	22.5	24.0	25.6	27.1	28.7	30.2
	112	2.8	4.4	6.1	7.8	9.4	11.1	12.7	14.4	16.1	17.7	19.4	21.1	22.7	24.4	26.1	27.7	29.4	31.0	32.7
120	3.0	4.8	6.6	8.4	10.1	11.9	13.7	15.5	17.3	19.1	20.9	22.7	24.5	26.3	28.1	29.8	31.6	33.4	35.2	



**Certified Ratings:**  
Pottorff certifies that the model SAJ-1235 shown herein is licensed to bear the AMCA seal. The ratings shown are based on test and procedures performed in accordance with AMCA Publication 511 and comply with the requirements of the AMCA Certified Ratings Program. The AMCA Certified Ratings seal applies to air performance and water penetration ratings.

## Pressure Loss

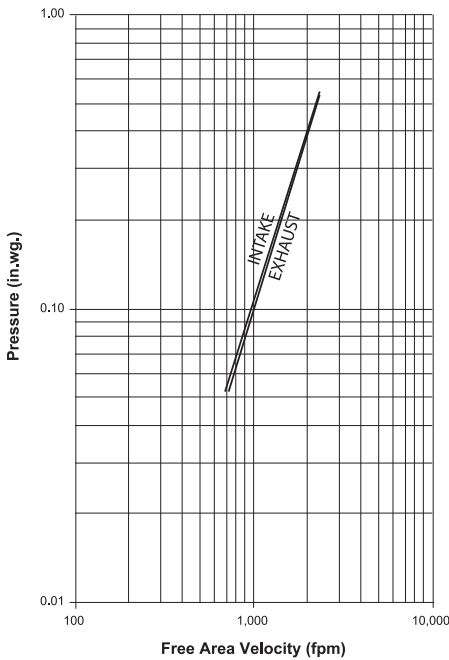

Louver Test Size = 48" x 48" (1219 x 1219)

## Selection Criteria

Follow the steps listed below to calculate the louver size needed to satisfy the required air volume while minimizing the adverse effects of water penetration and pressure loss.

1. Determine the Free Area Velocity (FAV) at the maximum allowable pressure loss using the *Pressure Loss* chart to the left. While job conditions vary, typically, the maximum allowable pressure loss should not exceed 0.15 in. wg., and the FAV for 0.15 in. wg. pressure loss is listed on the front page of this sheet.
2. **Intake Applications** If the FAV at the Beginning Point of Water Penetration (shown below) is less than the FAV from step 1, then use the FAV at the Beginning Point of Water Penetration in step 3, otherwise use the FAV from step 1.

**Exhaust Applications** Use the FAV from step 1 in step 3.

3. Calculate the total louver square footage required using the following equation.

$$\frac{\text{Required Air Volume}}{\text{cfm}} \div \frac{\text{FAV}}{\text{fpm}} = \frac{\text{Required Louver (Free-Area) Size}}{\text{ft}^2}$$

4. Using the *Free Area* chart above, select a louver width and height that yields a free area ft<sup>2</sup> greater than or equal to the required louver size calculated in step 3.

## Water Penetration

Beginning Point of Water Penetration = 924 fpm

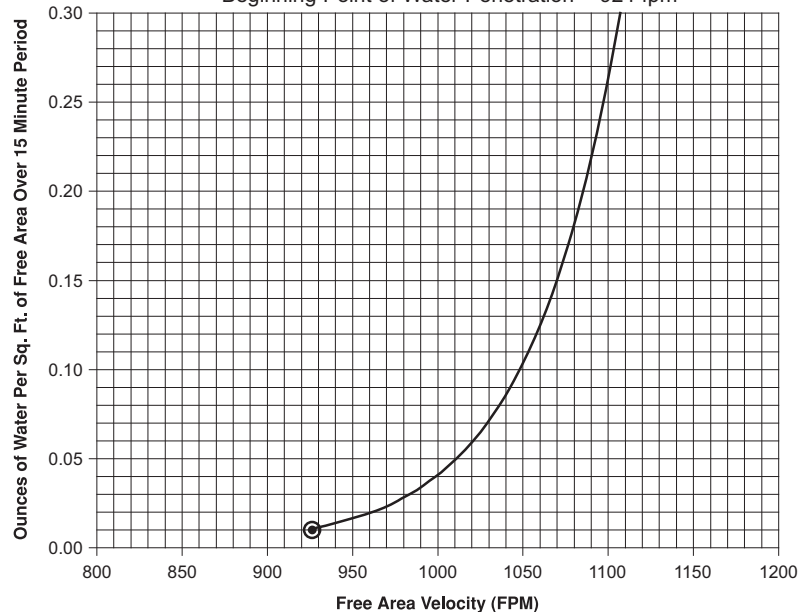

## Water Penetration

AMCA defines the beginning point of water penetration as the free area velocity at the intersection of a simple linear regression of test data and the line of 0.01 ounces of water per square foot of free area and is measured through a 48" x 48" louver during a 15 minute period. The AMCA water penetration test provides a method for comparing louver models and designs as to their efficiency in resisting the penetration of rainfall under specific lab conditions. Pottorff recommends that intake louvers are selected with a reasonable margin of safety below the beginning point of water penetration in order to avoid unwanted penetration during severe storm conditions.

Information is subject to change without notice or obligation.

NOTE: Dimensions in parentheses ( ) are millimeters.