

The following installation details apply to models **FSD-341, FSD-342, FSD-343, FSD-351 and FSD-352**

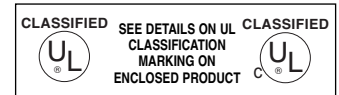
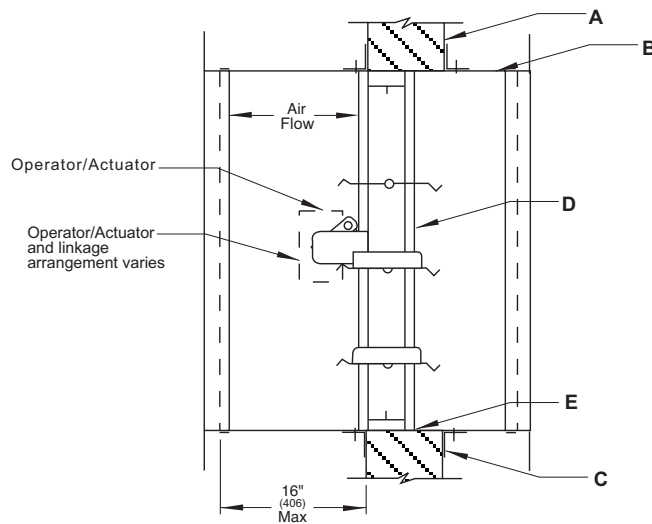

Notes:

- All dimensions shown in () are in millimeters.
- Illustration depicts damper installed vertical right side up. Damper may also be installed up side down.
- Illustration shows triple-V bladed (340 type), steel Airfoil blade (350 type) similar.

Vertical Mount

- Concrete or masonry fire partition shown. The opening shall be a minimum of 1/4" (6) with a maximum of 3/4" (19) larger than the overall damper and sleeve assembly size. When openings are larger than 3/4" (19), but less than 6" (152) the mounting angles must be a minimum of 16 gauge (1.5) and must be tall enough to overlap the opening by a minimum of 1" (25). Damper must be installed with leading edge of closed blade within the partition.
- For rigid type duct connections, the sleeve shall be a minimum of 16 gauge (1.5) for dampers up to 36" wide by 24" high (914 x 610) and 14 gauge (1.9) for larger units. When lighter gauge sleeves are used, one or more of commonly used breakaway style connections are required. Refer to Sleeve Termination Installation Instructions for further details. In no case will the sleeve gauge be less than the duct gauge to which it is connected. Damper sleeve shall not extend more than 16" (406) beyond the rated partition on the actuator side. The opposite side extension shall be a maximum of 6" (152) unless an access door is installed in the sleeve which then permits the extension to be a maximum of 16" (406).
- Mounting angles shall be a minimum of 1-1/2" x 1-1/2" x 16 gauge (38 x 38 x 1.5). Do not fasten or weld angles together at the corners. The angles shall be attached to the sleeve, not the partition, with 3/16" (4.8) diameter steel rivets, Quick-Lock Joints, welds, No. 10 (M5) bolts or sheet metal screws at 8" (203) o.c. maximum. A minimum of two connections per side, top and bottom. Mounting angles shall overlap the wall a minimum of 1" (25). A minimum 3/4" x 20 gauge (19 x 1) flange termination may be used in lieu of mounting angles on one side. Refer to Sleeve Termination Installation Instructions for further details. Ensure that attachment device does not interfere with the operation of the damper and the free movement of the damper blades.
- When joining multiple sections or fastening the damper to the sleeve, the damper shall be fastened with 3/16" (4.8) diameter steel rivets, Quick-Lock Joints, welds, or No. 10 (M5) bolts or sheet metal screws at 8" (203) o.c. maximum. A minimum of two connections per side, top and bottom. For joining multiple section high dampers, a minimum 14 gauge x 5" wide (1.9 x 27) supplemental steel mullion is required. The mullion must be the same length as opening/duct width. The mullion must be installed between the damper frames running parallel to the opening/duct width. Supplemental support mullions shall be attached to the damper frames using any of the same fasteners indicated previously in this section.
- A continuous bead of Dow-Corning 700 or 732, or GE RTV 108 or SCS 1201 RTV silicone rubber sealant shall be applied between the damper and the sleeve and between sections of a multiple damper assembly. Sealant is only required on one side of the damper.
- Fire/Leakage rated dampers and qualified operators are tested together by Underwriters Laboratories and are factory installed to qualify for standard damper/operator warranties. Damper operator/actuator must be tested prior to system start-up to ensure proper operation. Before applying power to the operator/actuator, the power must be verified.

Note:

The annular space between damper sleeve and wall opening must not be filled with firestop materials such as fill, void, or cavity materials. However, if optional sealing between the retaining angle (or flange) leg and the surface of the partition, wall, or floor and/or between the retaining angle leg and the surface of the damper sleeve is required, any of the following sealants may be used:
 Dow-Corning 700 or 732 GE RTV 108 or SCS 1201 RTV
 These sealants must be applied such that they do not intrude into the annular space between the outside surface of the damper sleeve and the opening of the partition, wall or floor into which the damper/sleeve is being installed.

DUCT SIZES	GALVANIZED STEEL		STAINLESS STEEL
	FSD-341, 342, 343	FSD-351, 352	FSD-342, 343
Maximum Single Section	36" x 48" (914 x 1219)	30" x 48" (762 x 1219)	36" x 48" (914 x 1219)
Maximum Multiple Section	108" x 96" * (2743 x 2438)	120" x 96" * (3048 x 2438)	N/A
Minimum	6" x 6" (152 x 152)	8" x 8" (203 x 203)	6" x 6" (152 x 152)

*Combination fire smoke damper sizes larger than 72" x 48" (1829 x 1219) or 36" x 96" (914 x 2438) require electric or pneumatic actuators and a HS-10 or DRS-30 fire closure device.

Underwriters Laboratories file #R11767

City of New York listing # MEA 295-98-E

The product is also listed by CSFM file # 3225-0368:110 and 3230-0368:111 and conforms to NFPA 90A and NFPA 92A.

Information is subject to change without notice or obligation.

NOTE: Dimensions in parentheses () are millimeters.